

TRUE BLUE ST2|3

ST2 becomes ST2|3

Same size, Same weight,
More light

- Now operates 3 kW lamps
- 65% more light, same housing
- Available only for 230 V

ARRI has taken a step toward making the True Blue Tungsten series even more versatile and attractive; the existing 230 V versions of the ST2 lamphead have been upgraded to ST2|3. This fixture now allows the operation of a 3000 W lamp in addition to the standard 2000 W lamps. The 3000 W lamp - namely the HX48 - has the same size and shape as the 2000 W lamp and therefore does not necessitate any mechanical adaptation of the housing.

Using a 3000 W lamp allows a 65% higher light output while maintaining the size and weight of the fixture. Modern studio dimmer systems have the capacity to support 3000 W, and in contrast to 5000 W lamps, this power class can be operated within the standard 16 V - 230 V power grid of most countries. This saves costs in cabling and energy, and purchase costs of the fixture itself.

Another possible scenario is a switch to HD recording systems, which are still less sensitive than SD cameras. In these situations the 2000 W lamps can simply be replaced with 3000 W lamps to provide the illumination headroom required.



Please note that US versions for 120 V will not be upgraded.

Order No.	Description
L3.40750.B	ST2 3 2000 W or 3000 W Studio Fresnel Lamphead, manual, blue/silver
L3.40755.B	ST2 3 2000 W or 3000 W Studio Fresnel Lamphead, manual, black
L3.40750.I	ST2 3 2000 W or 3000 W Studio Fresnel Lamphead, pole operated, blue/silver
L3.40755.I	ST2 3 2000 W or 3000 W Studio Fresnel Lamphead, pole operated, black
L3.40750.D	ST2 3 2000 W or 3000 W Studio Fresnel Lamphead, manual, blue/silver with Schuko plug
L3.40755.D	ST2 3 2000 W or 3000 W Studio Fresnel Lamphead, manual, black with Schuko plug
L3.40750.K	ST2 3 2000 W or 3000 W Studio Fresnel Lamphead, pole operated, blue/silver with Schuko plug
L3.40755.K	ST2 3 2000 W or 3000 W Studio Fresnel Lamphead, pole operated, black with Schuko plug
All the above are supplied with four leaf barndoor and filter frame.	

Accessories

L2.40950.0	Four Leaf Barndoor, black, rotatable, 344 mm
L2.40960.0	Eight Leaf Barndoor, black, rotatable, 344 mm
L2.80970.0	Filter Frame 330 mm
L2.80975.0	Variable Snoot
L2.80980.0	Set of 4 Scrims (without bag)
L2.88915.I	Scrim Bag
L2.76990.0	Safety Cable
L2.89079.0	4 m Operating Pole for pole-op fixtures
L2.88118.0	Barrel Clamp

Technical Specifications

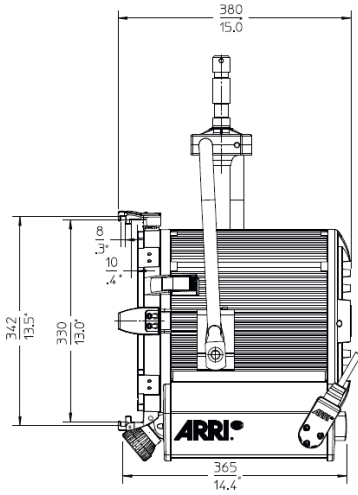

Lamps

CP41	2000 W	230 V	G38 Monoplane
CP73	2000 W	230 V	G38 Biplane
HX48	3000 W	230 V	G38 Monoplane

Specifications

Weight	10.5 kg manual, 11.5 kg pole op
Cable length	1.5 m
Lens Diameter	250 mm (10")
Lampholder	G 38
Reflector	Spherical specular high purity aluminium
Mounting	28 mm (1 1/8") spigot
Packed Size	550 x 510 x 510 mm / 21.65 x 20.08 x 20.08"
Protection Class	IP23
Certification	NRTL-US-C, CE, TÜV GS, CB

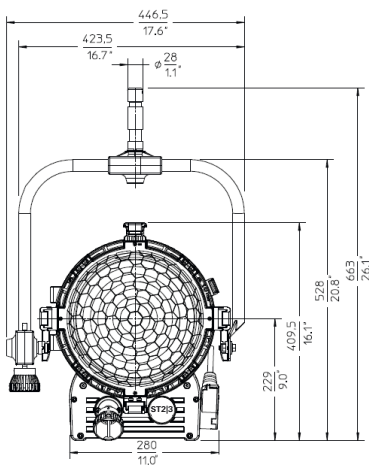

Photometric Data with 3000 W HX 48 lamp

Throw (m)	3	7	10
Spot: 11.6°	386 cd		
Output (lux)	42889	7878	3860
Medium: 30.2°	128 cd		
Output (lux)	14222	2612	1280
Flood: 56.3°	61 cd		
Output (lux)	6753	1240	608

Photometric Data with 2000 W CP/73 lamp

Throw (m)	3	7	10
Spot: 7.9°	377 cd		
Output (lux)	41889	7694	3770
Medium: 30°	76 cd		
Output (lux)	8422	1547	758
Flood: 56°	36 cd		
Output (lux)	4044	743	364

